



## Programming the Hysteresis Voltage Of Universal Voltage Monitors MC34161, MC33161 and NCV33161

Prepared by: Cimiy Chan  
ON Semiconductor

### APPLICATION NOTE

Device	Application	Input Voltage	Output Power	Topology	I/O Isolation
MC34161 MC33161 NCV33161	Universal Voltage Monitor	N/A	N/A	N/A	N/A

#### Circuit Description

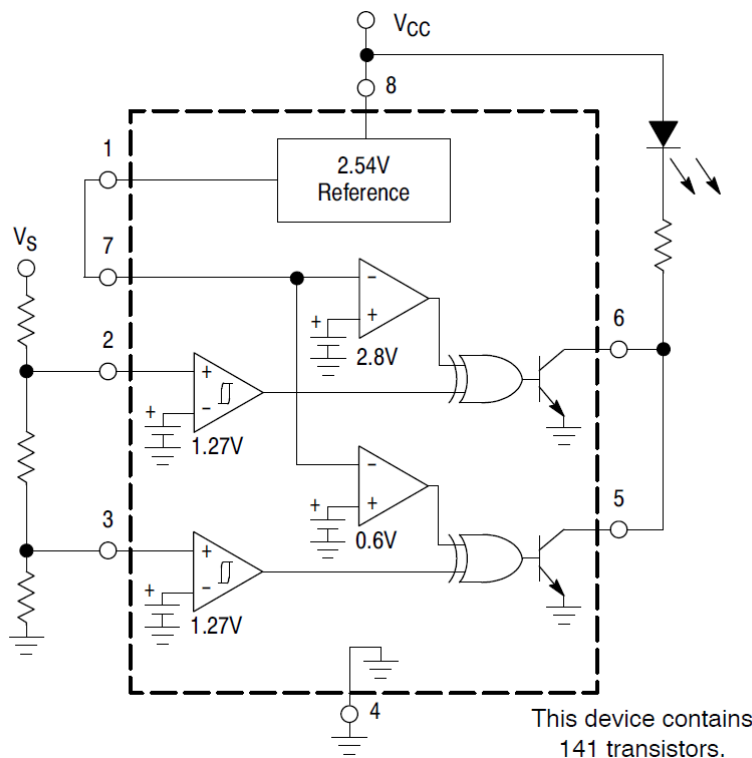

**Figure 1. General Block Diagram of MC34161/MC33161**

The Figure 1 shows the basic block diagram of MC34161/MC33161. It can be used for wide variety of voltage sensing application. They offer the circuit designer an economical solution for positive and negative voltage detection. The circuit consists of two comparators with hysteresis, a unique mode select input for channel programming, a output of 2.54 V reference, and two open collector outputs capable of sinking in excess of 10 mA.

Most of the comparators for the voltage monitoring provide hysteresis which is used for reducing the sensitivity to noise or a slowly moving input (low slew rate) signal. From the information of MC34161/MC33161 datasheet, the hysteresis is fixed to around 25 mV typically. However, this hysteresis value may not be enough for some applications for reducing the sensitivity

## AND8426/D

to noise or comparator input voltage fluctuation. For example, at the automotive application, the noise level or voltage fluctuation (divided down to comparator input) may be as high as 300 mV – 400 mV during system operating. Therefore, a comprehensive and easy way to increase the hysteresis is definitely a need for the MC34161/MC33161 application under high noise level.

This document demonstrates the steps to show how to program the hysteresis voltage. And also, simulation results together with laboratory bench test verification will be shown.

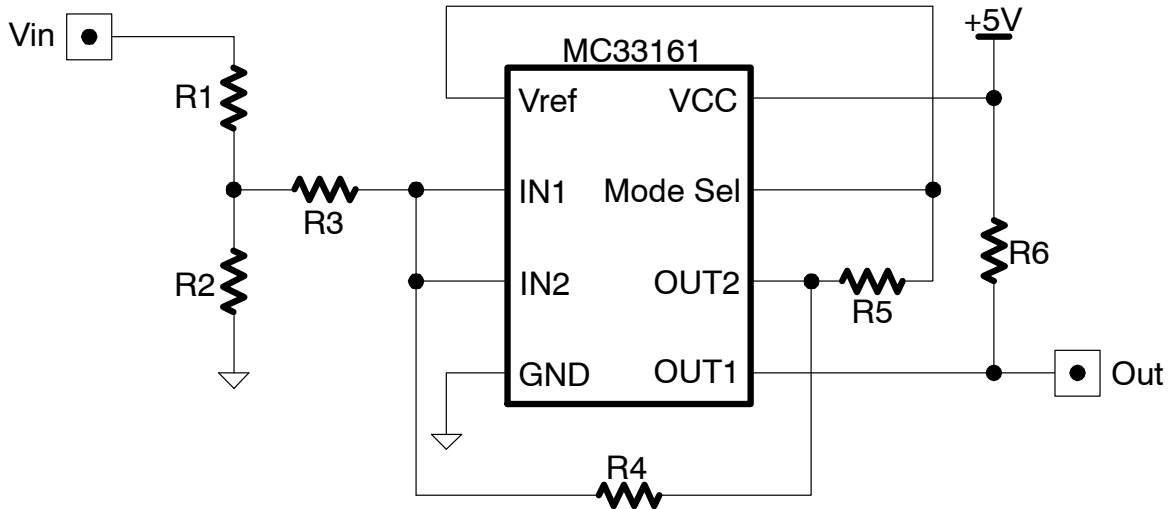

Figure 2. Schematic for Programming the Hysteresis Voltage

The configuration in the Figure 2 shows the circuit schematic for programming the hysteresis voltage. Basically, the hysteresis can be adjusted by varying R2, R3 and R4. Moreover, R1 and R2 are also used for the purpose of dividing down the external  $V_{IN}$  voltage. As mentioned before, R2, R3 and R4 can affect the amount of hysteresis voltage, it is necessary to find the easy way for the user to set the hysteresis voltage to fit for his own application. For R5 and R6, for typical application it sets as  $R5 = 200k$  and  $R6 = 10k$ .

From the circuit simulation result, it is found that R3 variation (fix R1, R2 and R4) can provide very good linear relationship with hysteresis voltage and Figure 3 depicts it:

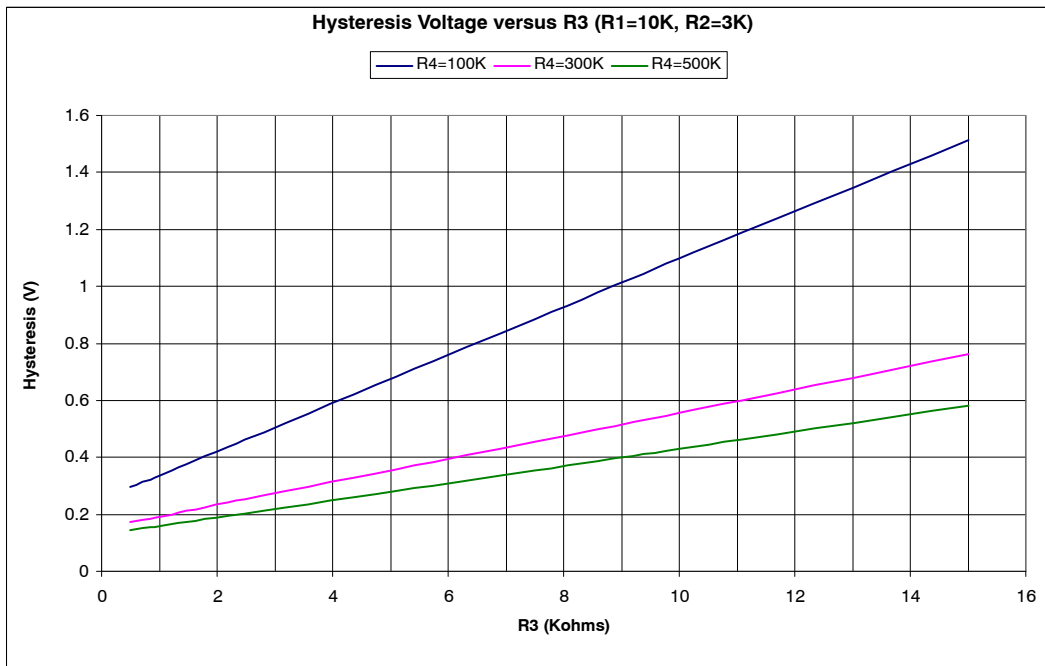

Figure 3. Chart to Show the Linear Relationship Between R3 and Hysteresis Voltage

## AND8426/D

For given  $V_{IN+}$  and  $\Delta V_{IN}$  (i.e. Hysteresis Voltage) with fixed  $R_2$  and  $R_4$ , we are required to evaluate  $R_1$  and  $R_3$  to complete the system configuration. The charts shown at next page will help us how to evaluate  $R_1$  and  $R_3$ . All the equations attached at charts are formed by the method of linear regression using known values which are acquired from simulation results.

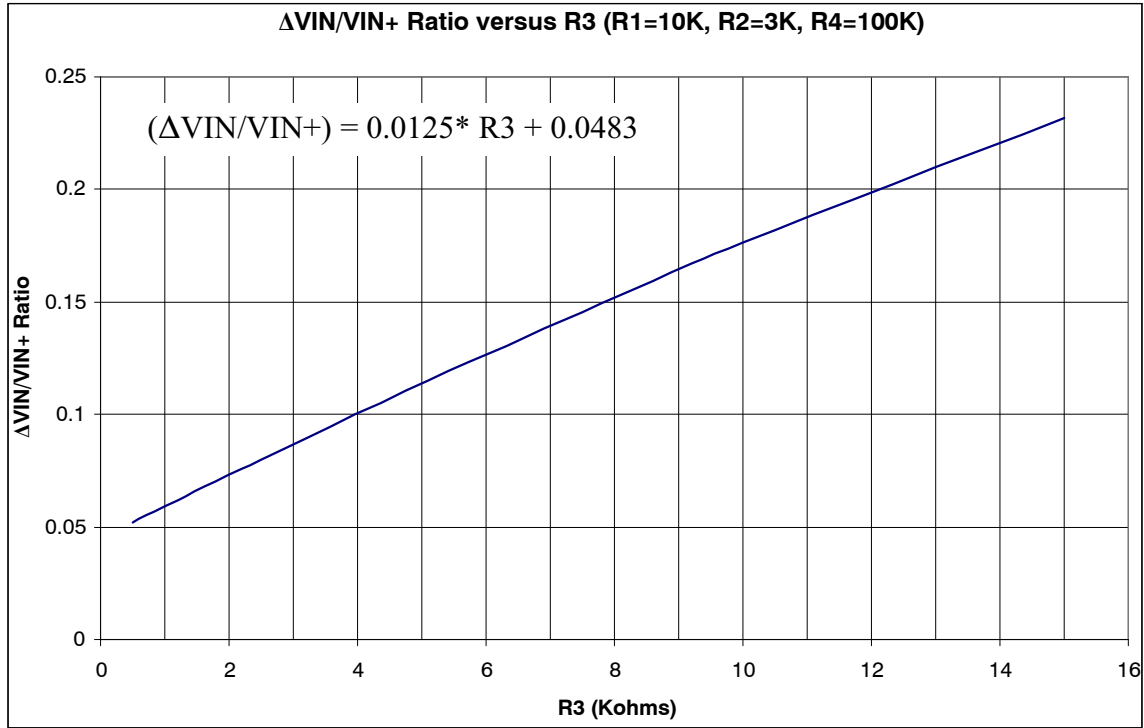

Figure 4. Chart for  $\Delta V_{IN}/V_{IN+}$  Ratio versus R3

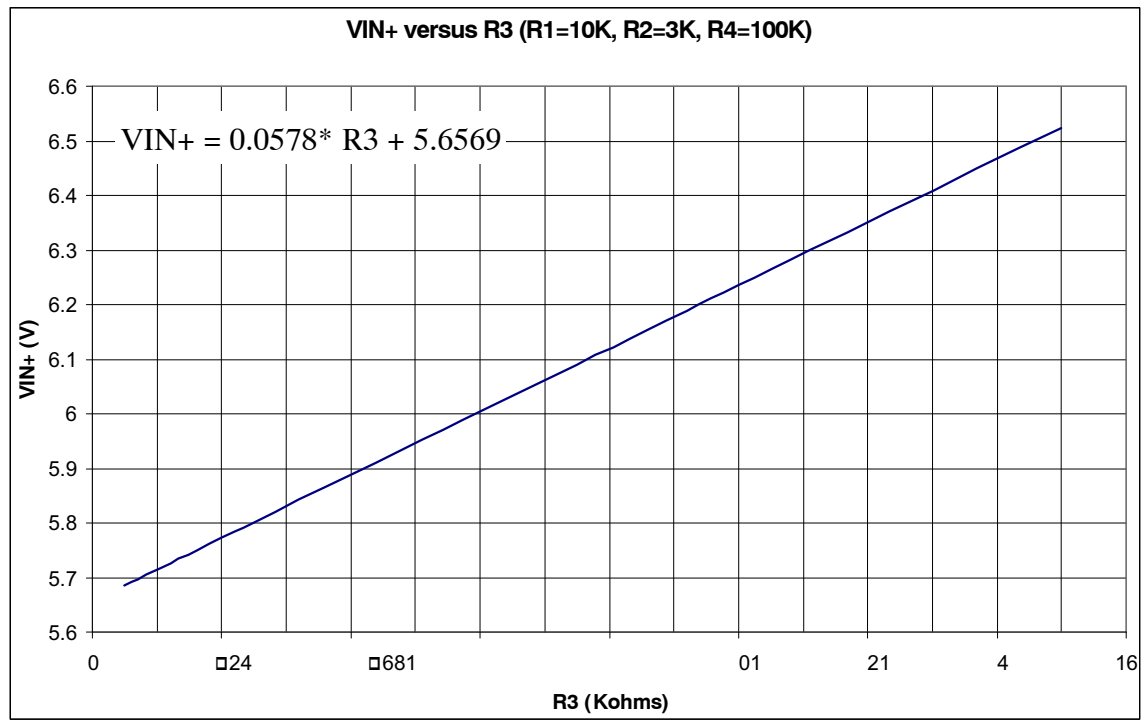

Figure 5. Chart for  $V_{IN+}$  versus R3

## AND8426/D

### Steps to Evaluate R1 and R3 for Given $V_{IN+}$ and $\Delta V_{IN}$

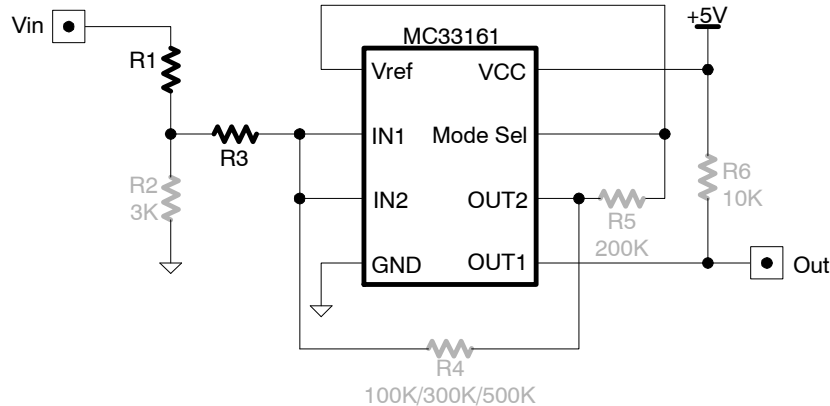

Figure 6. Circuit for Evaluation of R1 and R3

1. Fix  $R2 = 3k$ ,  $R4 = 100k/300k/500k$  (see step 3 for detail)
2. For given  $V_{IN+}$  and  $\Delta V_{IN}$ , calculate the ratio of  $\Delta V_{IN}/V_{IN+}$ .
3. From Figure 4 chart with make use of the equation provided, evaluate  $R3$  based on the calculated  $\Delta V_{IN}/V_{IN+}$ . If  $R3$  is found to be negative, try to use  $R4 = 300k$  (use Figure 10) or  $R4 = 500k$  (use Figure 12) and repeat  $R3$  evaluation.
4. From Figure 5 (if  $R4 = 300k$ , use Figure 11. If  $R4 = 500k$  use Figure 13) chart with make use of the equation provided, evaluate  $V_{IN+}'$  based on the  $R3$  which is defined at step 3, say  $V_{IN+}'$ . It should be noted that the  $V_{IN+}'$  value here is NOT the one that will be used, it is just for intermediate value to proceed the calculation.
5. Evaluate  $R1'$  based on the formula:  $(V_{IN+}') * (R1' + R2) = (V_{IN+}) * (R1 + R2)$  where  $R1 = 10k$ ,  $R3 = 3k$ .
6. So,  $R1$  (notate as  $R1'$  at step 5),  $R2$ ,  $R3$  and  $R4$  are evaluated.

#### Example

The customer wants to have the application of which Output is low when  $V_{IN} = 3V$  and output is high when  $V_{IN} = 2.75V$ .

**Step 1:** Fix  $R2 = 3K$ ,  $R4 = 100k$

**Step 2:**  $V_{IN+} = 3V$  and required hysteresis  $\Delta V_{IN}$   
 $= 3 - 2.75$   
 $= 0.25V$   
 So the  $(\Delta V_{IN}/V_{IN+})$  ratio  $= 0.25 / 3$   
 $= 0.0833$

**Step 3:** From the Figure 4 chart with make use of equation, we have  
 $0.08333 = 0.0125 * R3 + 0.0483$   
 Therefore,  $R3 = (0.08333 - 0.0483)/0.0125$   
 **$R3 = 2.803k$**

**Step 4:** From the Figure 5 chart with make use of equation, we have  
 $V_{IN+}' = 0.0578 * 2.803 + 5.6569$   
 $V_{IN+}' = 5.819V$

**Step 5:** Evaluate  $R1$  by the formula mentioned at step 5,  
 $5.819 * (R1 + 3) = 3 * (10 + 3)$   
 **$R1 = 3.702k$**

So, the system will give  $V_{IN+} = 3V$  with  $\Delta V_{IN} = 0.25V$  for  $R1 = 3.702k$ ,  $R2 = 3k$ ,  $R3 = 2.803k$ ,  $R4 = 100k$ .

# AND8426/D

## Validation by PSPICE Simulation

Now, we put those resistor values into PSPICE for functional validation.

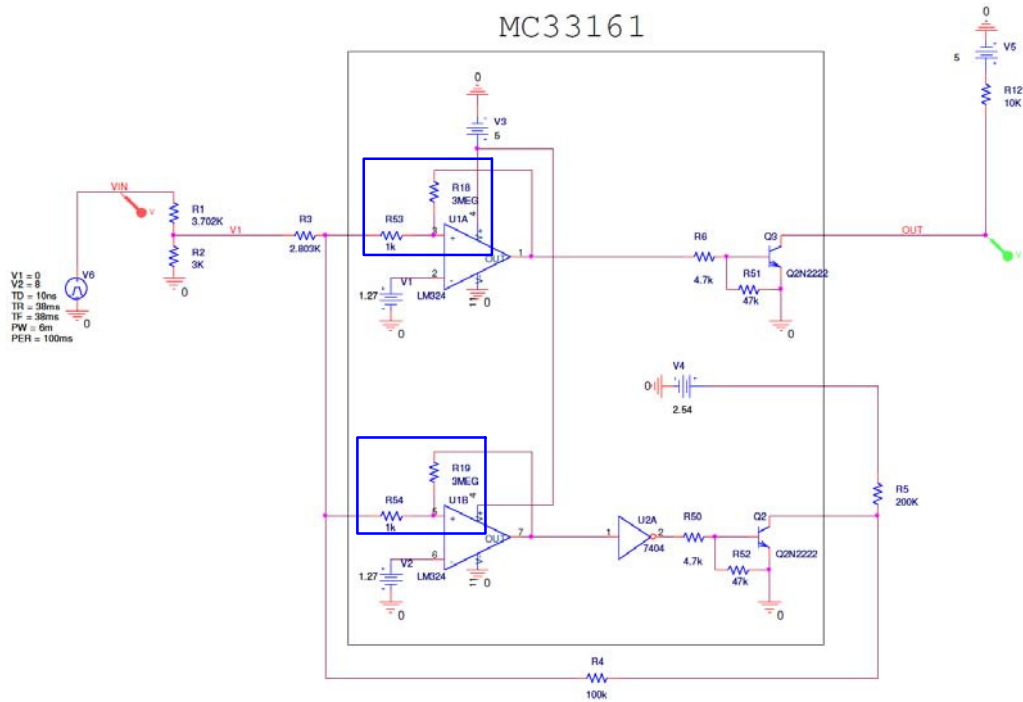

Figure 7. MC33161 PSPICE Schematic Model

Note: For the comparators portion, LM324 (U1A/U1B), R18(R19) and R53(R54) are used to provide 25 mV hysteresis which is the “intrinsic” amount per datasheet quoted. And input characteristics of LM324 is quite similar to those of real MC33161.

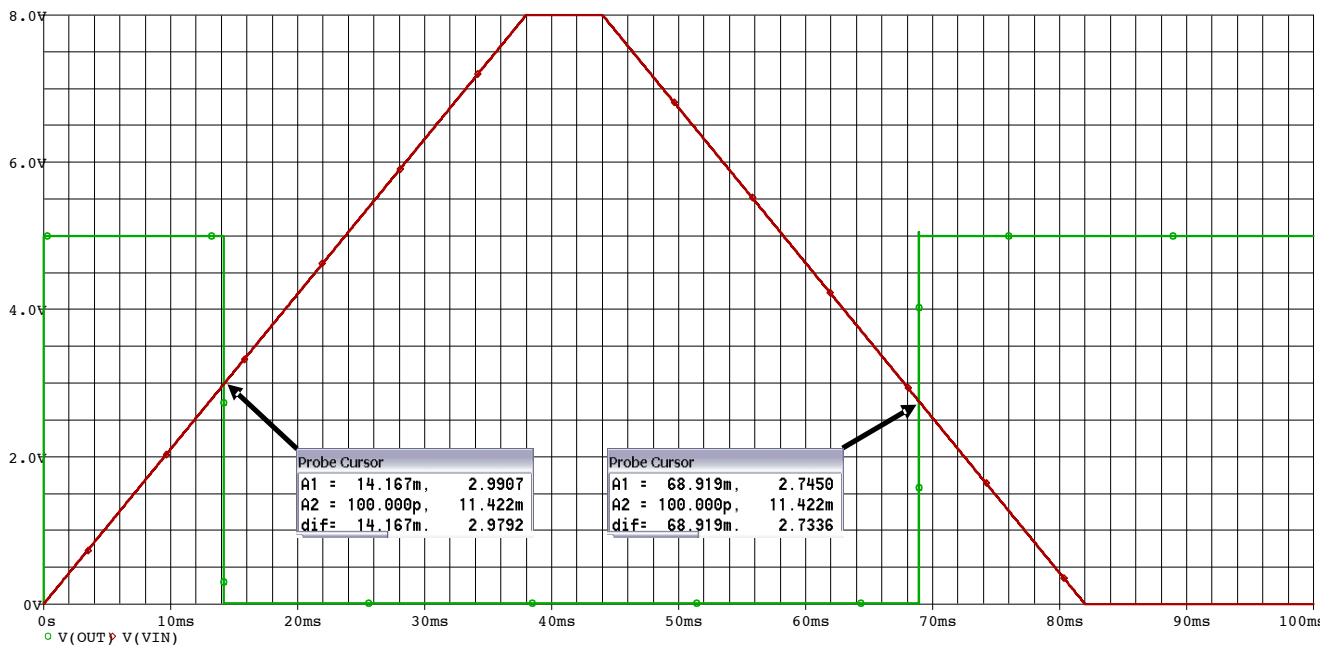

Figure 8. Simulation Result ( $V_{IN+} = 2.9907\text{ V}$ ,  $V_{IN-} = 2.7450\text{ V}$ ,  $\Delta V_{IN} = 2.9907 - 2.7450 = 0.2457\text{ V}$ )

So, the simulation result is consistent with theoretical calculation.

### Validation by Laboratory Evaluation

Recall the resistor sets R1 to R4

R1 = 3.702k

R2 = 3k

R3 = 2.803k

R4 = 100k

At laboratory, the following resistor values are used:

R1 = 3.6k + 100 Ω = 3.70k

R2 = 3k

R3 = 2.7k + 100 Ω = 2.80k

R4 = 100k

All resistors are tolerance 1%

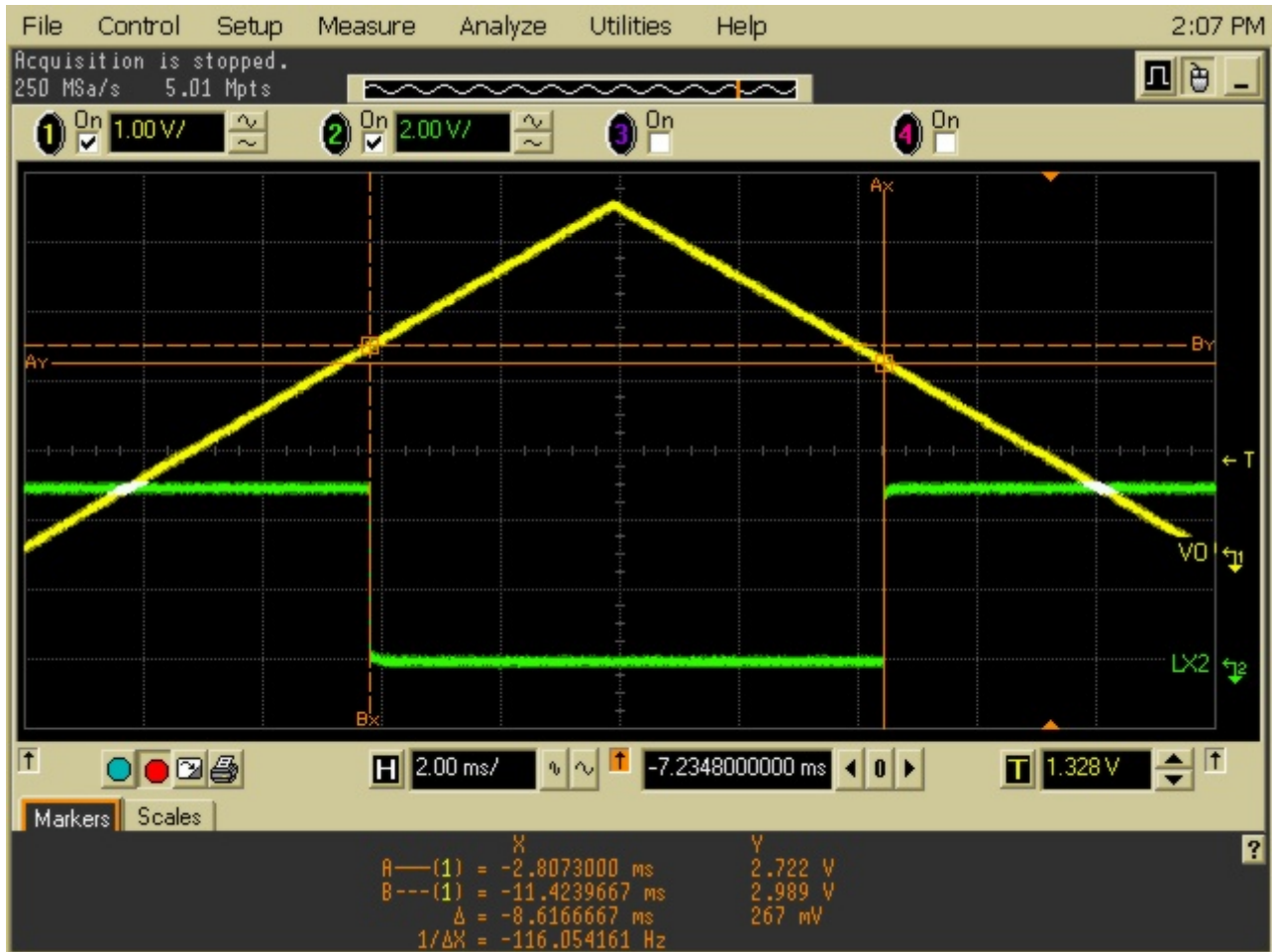

Figure 9. Scope Capture ( $V_{IN+} = 2.989$  V,  $V_{IN-} = 2.722$  V,  $\Delta V_{IN} = 2.989 - 2.722 = 0.267$  V)

So the evaluation result in laboratory bench is also consistent with theoretical calculation.

### Cautions For Selection of Resistor R3 to R4

1. R3 should be used lower than 15k, otherwise there will have some non linear behavior with either  $V_{IN+}$  or  $\Delta V_{IN}/V_{IN+}$
2. R4 should be used higher than 100k.

The following charts provide  $V_{IN+}$  and  $\Delta V_{IN}/V_{IN+}$  versus R3 for R4 = 300k and R4 = 500k. Those may be used if  $\Delta V_{IN}/V_{IN+}$  are too small for R4 = 100k configuration.

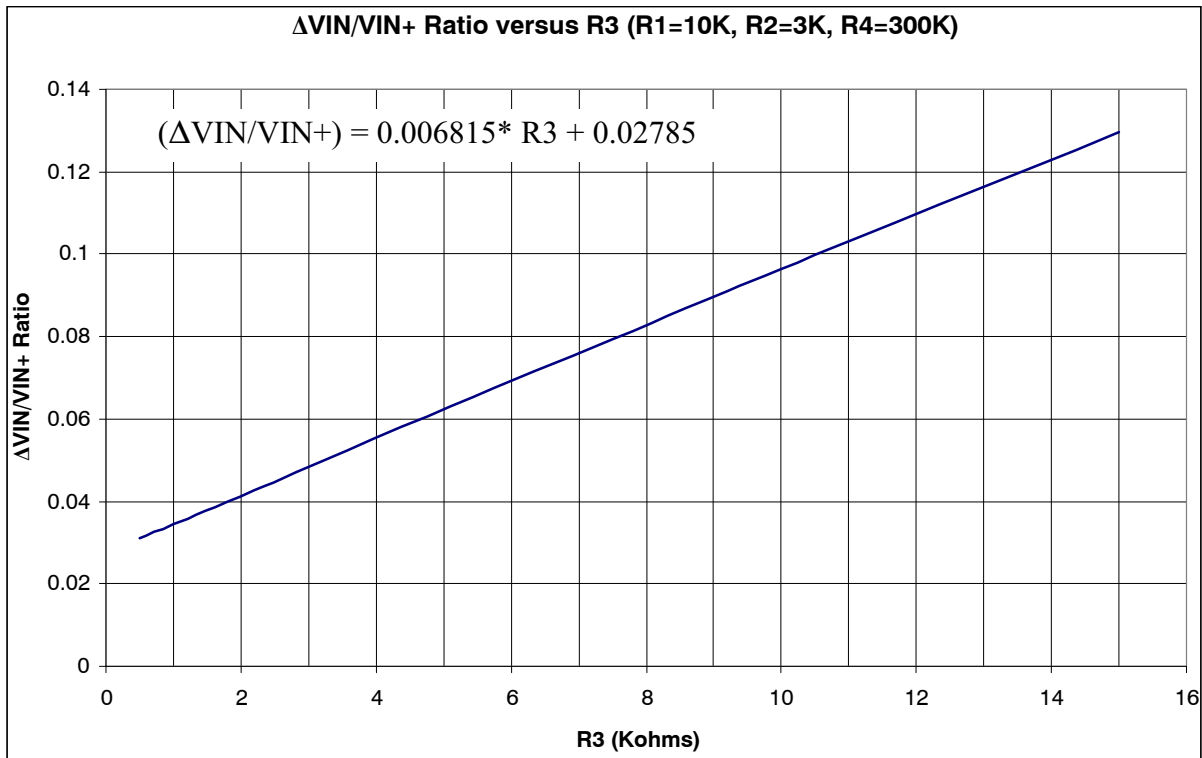

Figure 10. Chart for  $\Delta V_{IN}/V_{IN+}$  Ratio versus R3 (R4 = 300k)

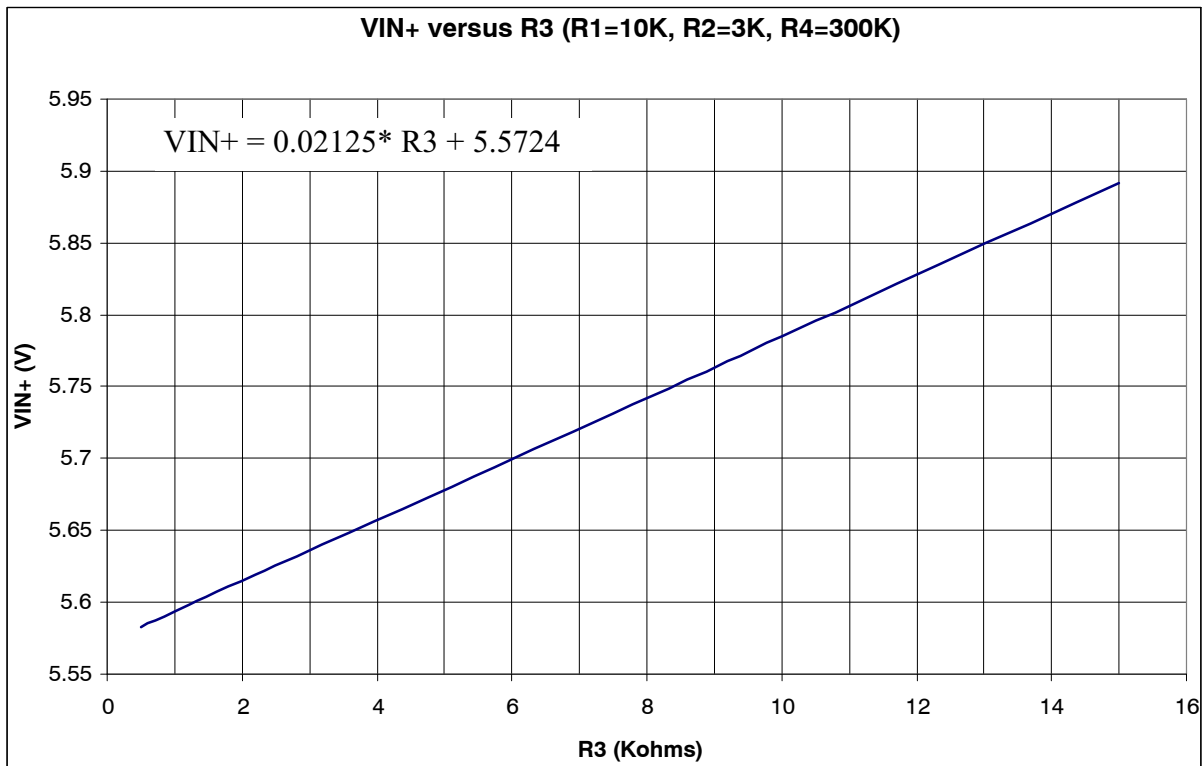

Figure 11. Chart for  $V_{IN+}$  versus R3 (R4 = 300k)

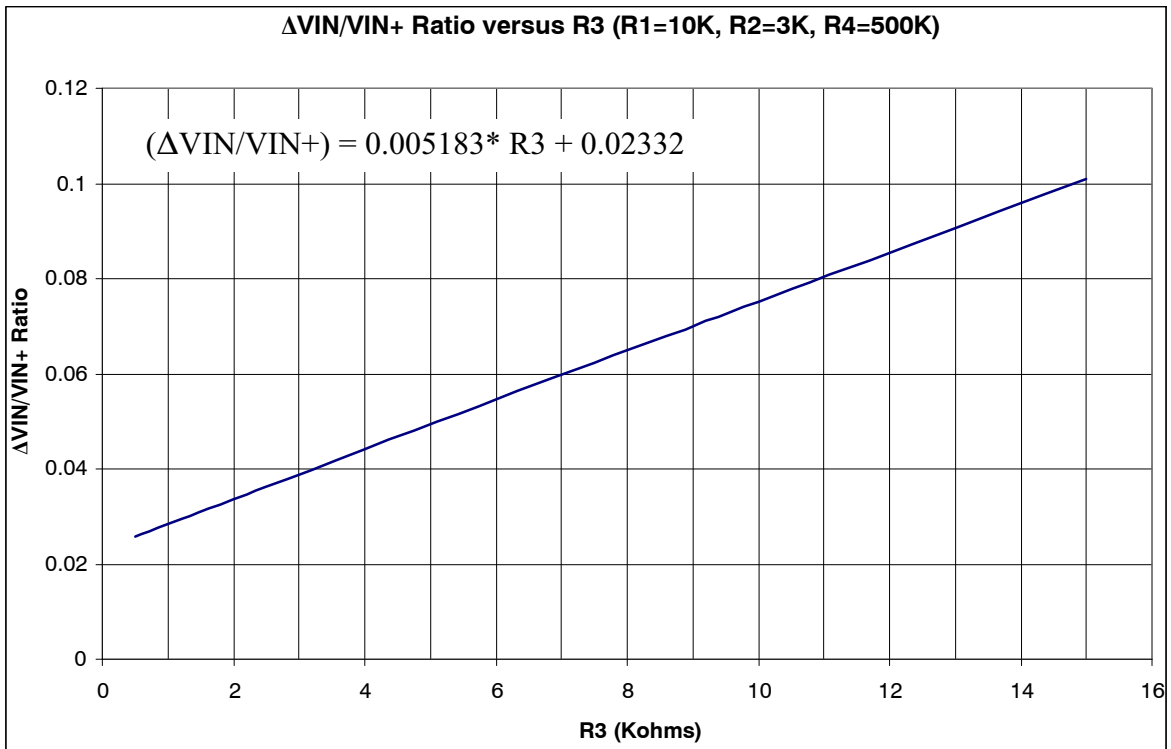

Figure 12. Chart for  $\Delta V_{IN}/V_{IN+}$  Ratio versus R3 (R4 = 500k)

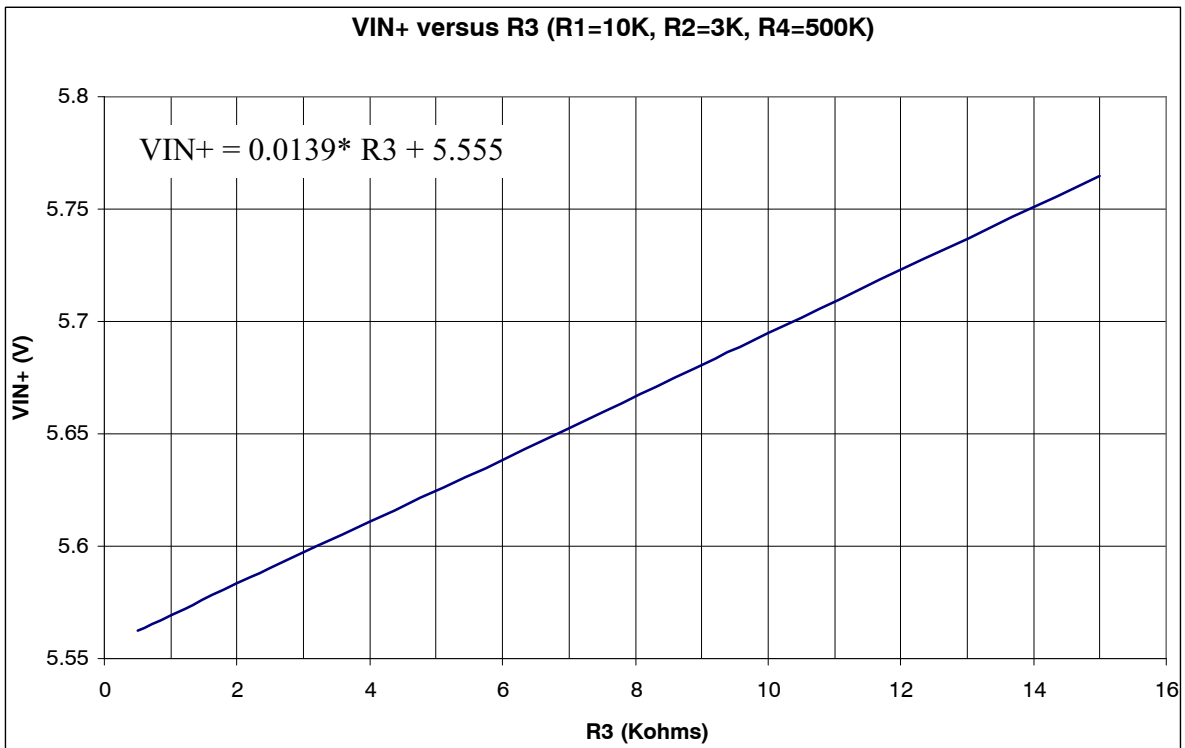

Figure 13. Chart for  $V_{IN+}$  versus R3 (R4 = 500k)



**ON Semiconductor** and  are registered trademarks of Semiconductor Components Industries, LLC (SCILLC). SCILLC reserves the right to make changes without further notice to any products herein. SCILLC makes no warranty, representation or guarantee regarding the suitability of its products for any particular purpose, nor does SCILLC assume any liability arising out of the application or use of any product or circuit, and specifically disclaims any and all liability, including without limitation special, consequential or incidental damages. "Typical" parameters which may be provided in SCILLC data sheets and/or specifications can and do vary in different applications and actual performance may vary over time. All operating parameters, including "Typicals" must be validated for each customer application by customer's technical experts. SCILLC does not convey any license under its patent rights nor the rights of others. SCILLC products are not designed, intended, or authorized for use as components in systems intended for surgical implant into the body, or other applications intended to support or sustain life, or for any other application in which the failure of the SCILLC product could create a situation where personal injury or death may occur. Should Buyer purchase or use SCILLC products for any such unintended or unauthorized application, Buyer shall indemnify and hold SCILLC and its officers, employees, subsidiaries, affiliates, and distributors harmless against all claims, costs, damages, and expenses, and reasonable attorney fees arising out of, directly or indirectly, any claim of personal injury or death associated with such unintended or unauthorized use, even if such claim alleges that SCILLC was negligent regarding the design or manufacture of the part. SCILLC is an Equal Opportunity/Affirmative Action Employer. This literature is subject to all applicable copyright laws and is not for resale in any manner.

## PUBLICATION ORDERING INFORMATION

### LITERATURE FULFILLMENT:

Literature Distribution Center for ON Semiconductor  
P.O. Box 5163, Denver, Colorado 80217 USA  
**Phone:** 303-675-2175 or 800-344-3860 Toll Free USA/Canada  
**Fax:** 303-675-2176 or 800-344-3867 Toll Free USA/Canada  
**Email:** [orderlit@onsemi.com](mailto:orderlit@onsemi.com)

**N. American Technical Support:** 800-282-9855 Toll Free  
USA/Canada  
**Europe, Middle East and Africa Technical Support:**  
Phone: 421 33 790 2910  
**Japan Customer Focus Center**  
Phone: 81-3-5773-3850

**ON Semiconductor Website:** [www.onsemi.com](http://www.onsemi.com)  
**Order Literature:** <http://www.onsemi.com/orderlit>  
For additional information, please contact your local  
Sales Representative